

BEST Kit Basics

(adapted with permission, “kit_notes”, Terry Grimley, San Antonio BEST, all copyright reserved. Please contact original author if you wish to use this information in a context outside of BEST)

The term “kit” refers to all the parts and materials that are allowed to be used on a BEST robot. Not all parts issued to you by BEST can be used on the robot during competition (e.g., battery chargers and packing materials). And BEST does not issue 100% of the materials that can be used (e.g., golf balls, aluminum can, and wire hanger). The official definition of the kit is described each year by a detailed list of parts (most of which are provided to your team by your local BEST Hub). The list of parts is actually divided into two sections, the “consumable” kit list, and the “returnable” kit list. As the name implies, all parts in the Returnable Kit must be returned to the Hub after the competition is over. The Returnable Kit basically consists of the electronics and some gear/pulley components. The Consumable Kit consists of plywood, sheet plastic, fasteners, adhesives, and miscellaneous hardware.

Your local Hub will distribute detailed Kit information at the Kickoff event. The summaries here are simply to convey the scope of the Kit.

Returnable Kit (RK) Notes Summary (refer to the images on the next two pages for many of the parts):

- All items in the RK must be returned without any alteration.
- The Remote Control system includes a 4-channel radio frequency transmitter and a receiver. This means that the operator can generally control four different robot actions at any given time.
- Batteries: Though two rechargeable batteries are included in the RK, only one can be used on the robot at any given time. Read the detailed information provided by your Hub carefully because the batteries can be permanently damaged if they are not charged properly.
- Speed Controllers are used to precisely control the speed of a motor. Though you have four motors in the RK, there are only two speed controllers. The other two motors will probably be controlled using all-on (or all-off) switches.
- There are only 30 different frequencies available for the remote controls that we use in BEST. Therefore, hubs with a large number of teams (30 or more) have to implement a secondary control system to prevent interference between the many different controllers that are present at game day. This system is called the “Tether System.” There is some rudimentary information about the Tether System at the end of this document. The images on the next pages include some of the tether system components.

Consumables Summary:

A current Consumable Kit list can probably be downloaded from your local hub’s website. An partial example has been appended to the end of this document.

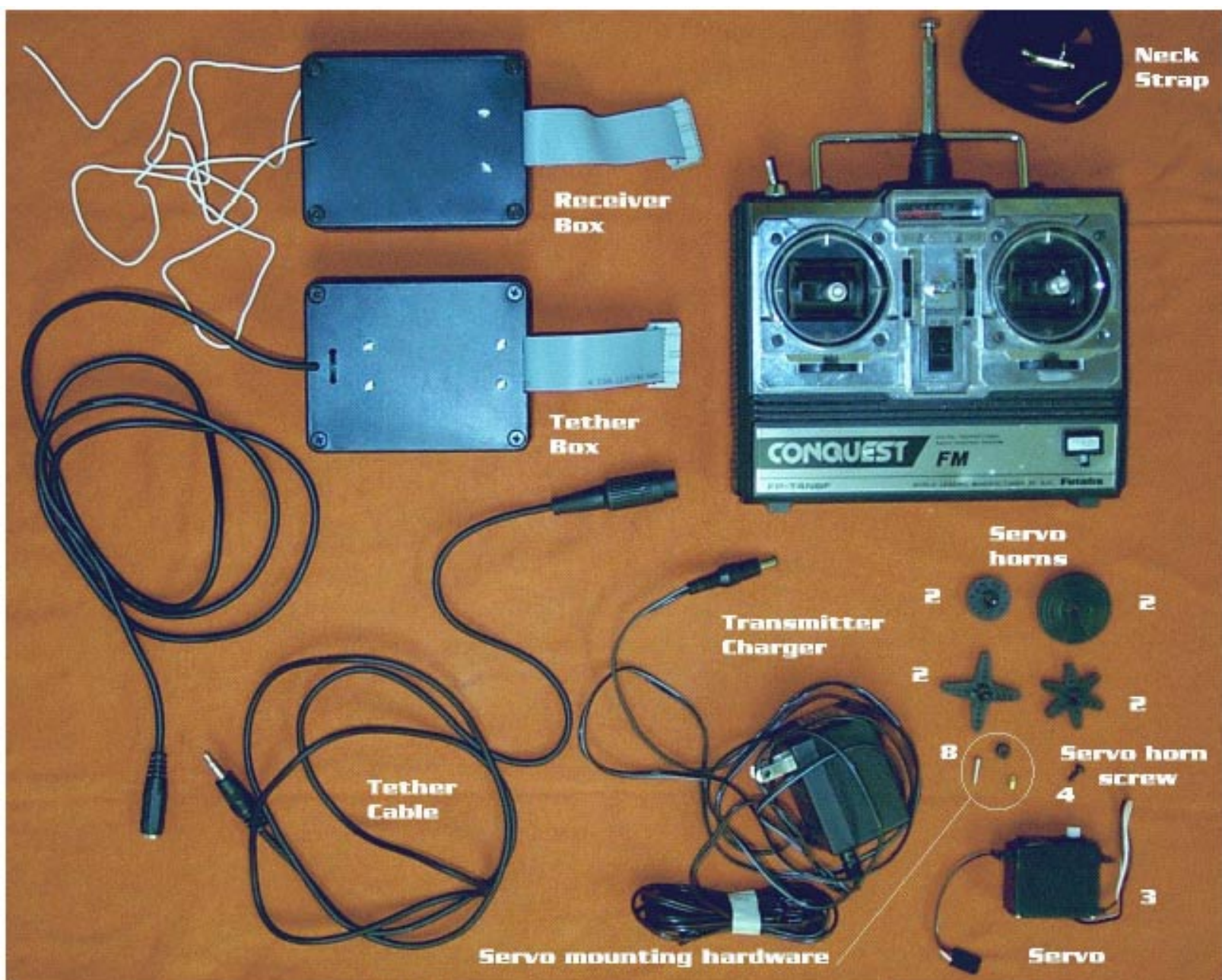

You may recognize that the remote controller is a very typical model airplane controller. The “servo” is simply a DC motor that can only turn to set positions. So, if the servo horns are mounted on the servo, and the servo is connected to the receiver (through the robot box on the next image) then the servo horn will rotate to different positions to match the position of the remote control joystick as dictated by the operator.

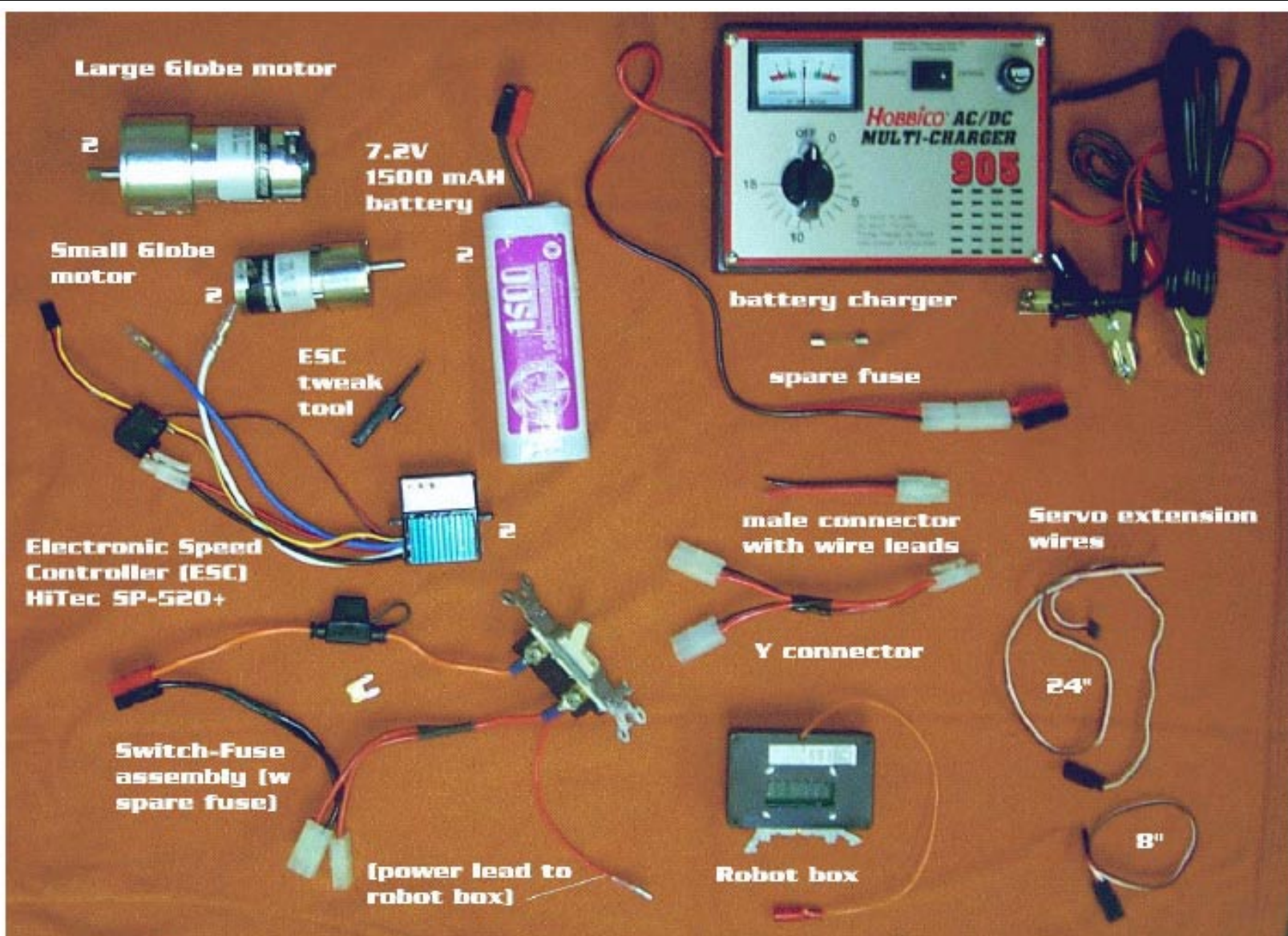

There are two sizes of motors shown above. In addition to two of each size, the RK includes three servo motors (shown on the previous page). Together, these motors provide the team with many options to control the movement of their machine.

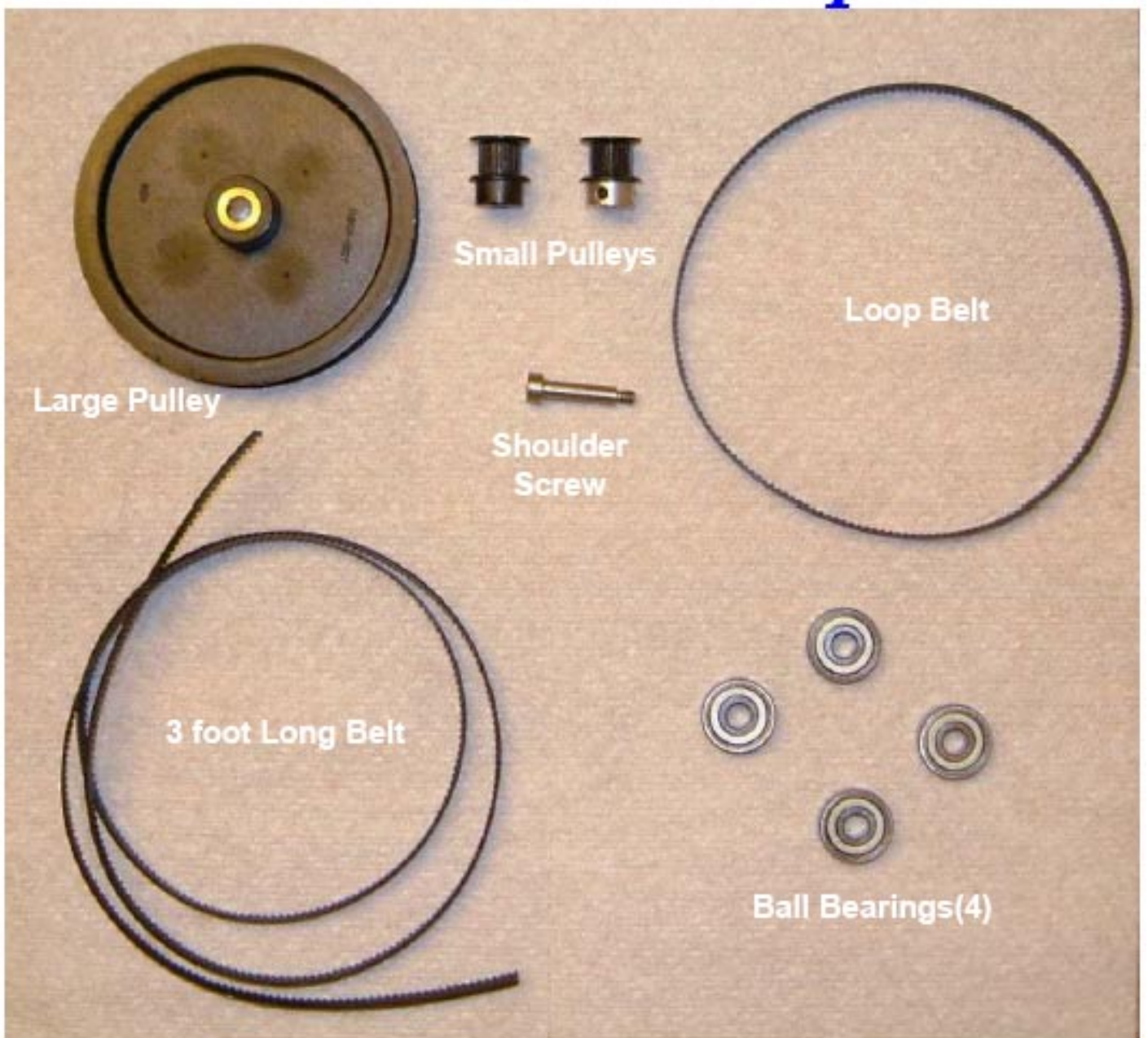

The RK also includes some mechanical parts to help the teams create various gearing configurations. Using the toothed belts the motor speed can be geared up or down. Friction can be reduced using the supplied bearings.

Wiring Information

Figure 1 shows a suggested wiring diagram and includes the required "Y" connector on/off switch harness. This harness includes a fuse and provides an on/off switch for all of your robot's electrical power. Do not bypass the fuse. If you blow a fuse, determine why before replacing it. A replacement fuse **may be** included in your kit. Additional replacement fuses (only use the same rating fuse) can be found at auto-supply stores. The 5 cent fuse protects the **\$80** (or more) speed controllers!

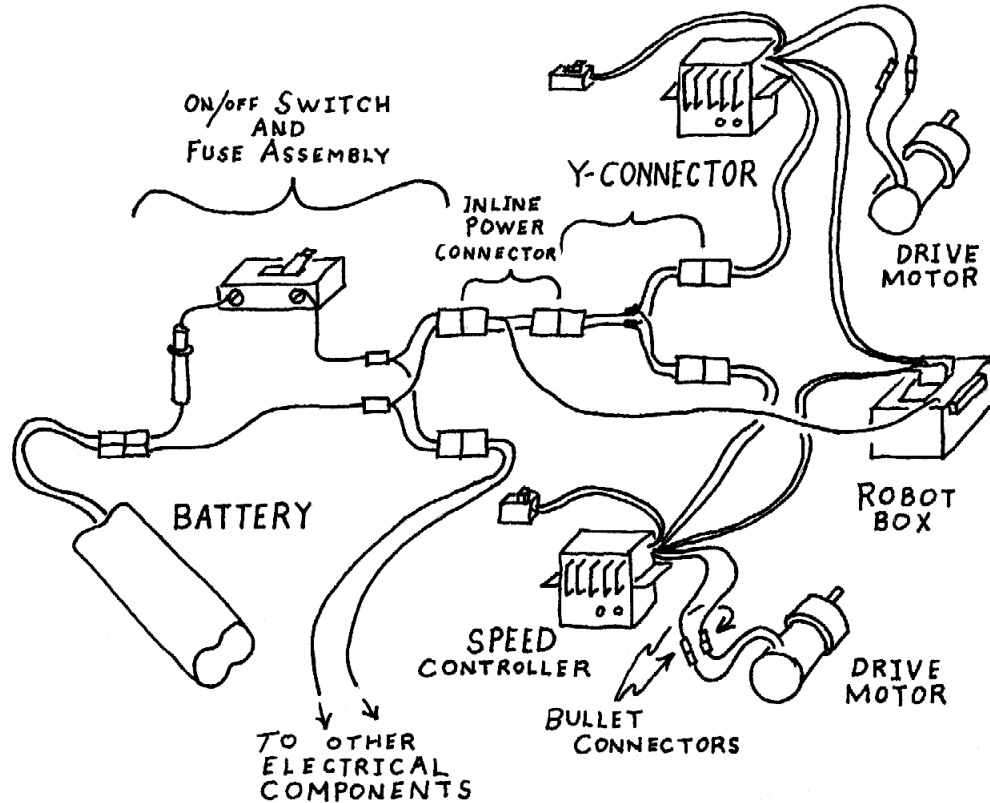

Figure 1 – Suggested wiring diagram (Note: the robot box is replaced by the R/C receiver for a non-tether system).

The on/off switch and fuse assembly is required and will be checked during kit compliance check-in. If it is not in place, you will need to add it. The on/off switch should be easy to access and labeled so that a referee can switch off your machine, should the need arise during a match.

You **may** also need to make your own motor connectors. Included in the kit are 6 "bullet" connectors. These should mate with the connectors coming from the speed controller. Attach these bullet connectors to a length of wire and then solder them to the motor tabs. **Do not cut the bullet connectors off of the speed controllers! Also do not crush the bullet connectors.**

Using the Microswitches

Included in the kit are 4 microswitches that can be used to control additional motors in the kit. Figure 4 shows a method for using a servo to activate the switches. This setup will run a motor in either direction depending on joystick position. Since 4 microswitches are included in the kit, two of these setups can be constructed. Use the included double pigtail to supply power to your microswitch assembly(s).

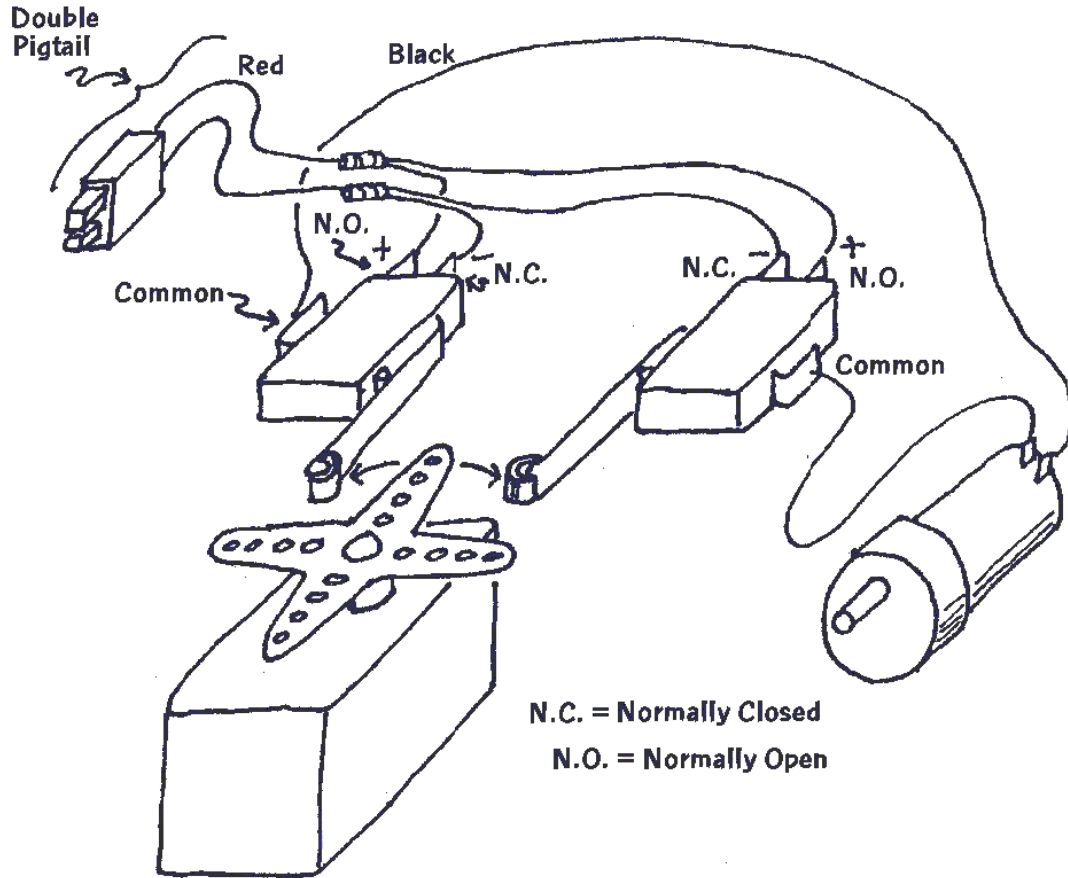

Figure 2 – Microswitch Setup for switching motor direction.

Servo Notes

If a servo is "humming" this indicates the load on the servo is more than it was designed to handle. This will cause the battery to drain quickly and may damage the servo. Readjust the servo travel and/or its linkage so the servo does not hum. Do not open the servos. If you suspect the servo is damaged contact your BEST kit representative.

Wheel Attachment

(or whatever needs to be attached to a motor)

Figure 3 shows one suggested method for wheel attachment that has been reliable in the past. This is not the only way to connect wheels, just a suggestion.

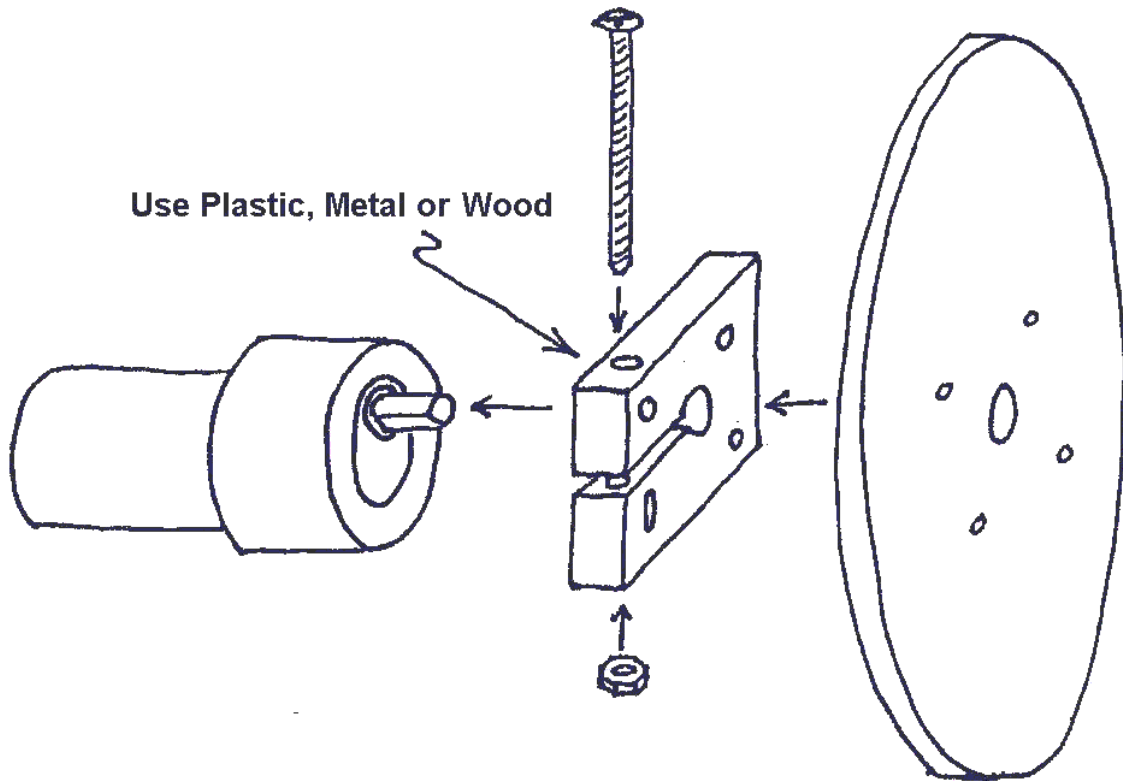

Figure 3 – One suggestion for mounting wheels

Tether System Basics

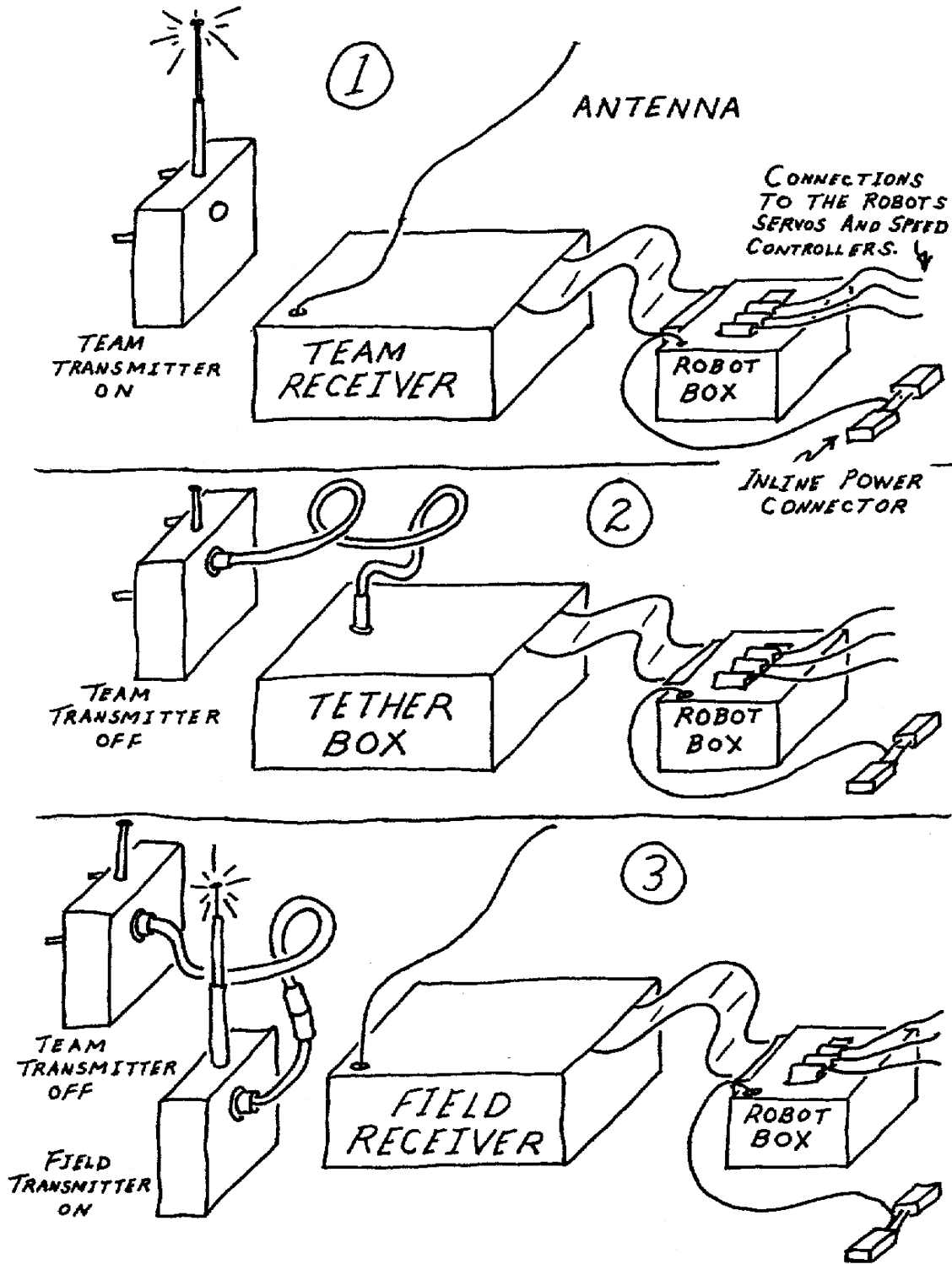

Figure 4: Three Modes of Tether System

Components of the tether system and its three modes are shown in Figure 4. In mode 1, which is used during the 6 week build and test time, the system works like a conventional Radio/Control (R/C) system. Your R/C transmitter broadcasts your control commands to the robot's receiver on its particular frequency. Inside the Team Receiver box is the matching R/C receiver for your transmitter. It receives the broadcast signal and translates it into servo commands. These commands travel through a flat ribbon cable to the Robot Box. Once in the Robot Box the signals are connected to the servos and speed controllers of the robot making it do all the wonderful things your robot does under your control. Figure 5 shows the channel assignments for the Robot Box and the orientation of the servo connectors. To power this system an inline power connector is placed on the output of the on/off switch assembly supplied in your kit. This power hookup is shown in Figure 1.

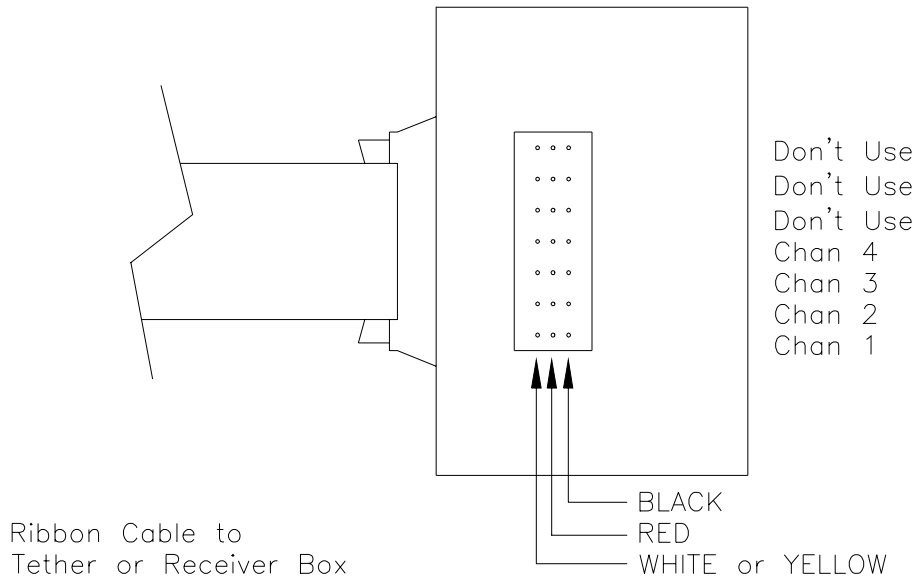
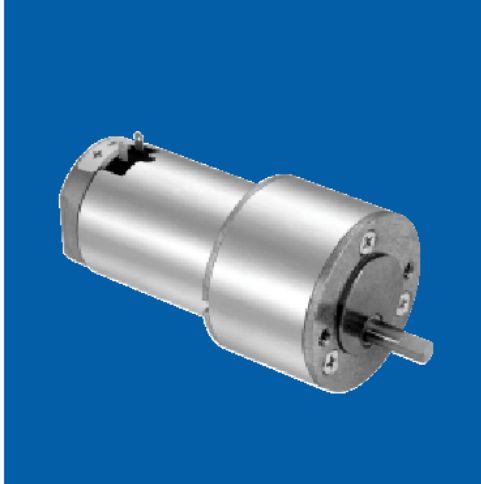

Figure 5 Connecting Servos and Speed Controllers to the Robot Box

IM-15 GEARMOTORS

DC Permanent Magnet Spur Gearmotors

E-2435



torque rating: Standard sintered gear strength to 300 oz. in. Optional cut gears add strength and durability

weight: 15 to 16.5 ounces

gears: Precision high density sintered gear

shaft: Precision-ground; through hardened AISI 1137-1141 steel. Options: length, flats, pinions, gears. Shaft material may change depending upon options selected

bearings: Motor and gearbox bearings are life-lubricated sleeve bearings. Ball bearing option available

gearbox cover: Steel housing, zinc plate

mounting flange: Die-cast zinc

options available:

- Ball bearings
- Leads
- EMI suppression
- Square mounting flange

Dimensions

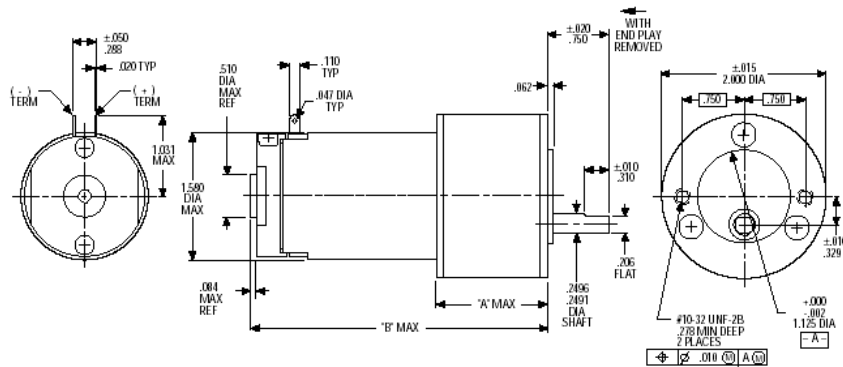

ROTATION (SEE CHART, OPPOSITE PAGE) VIEWED FROM SHAFT END WITH POSITIVE VOLTAGE ON (+) TERMINAL. REVERSE POLARITY FOR OPPOSITE ROTATION

NOTE: Consult factory prior to preparing spec control prints. Dimensions are for reference only

Example of a Consumable Kit

2004 BEST Consumable List (provided by hub)	
Qty	Description
1 ea	15/32" or 1/2", 2'X4' plywood, BC or Luan grade
1 ea	11/32" or 3/8", 2'X4' plywood, BC or Luan grade
1 ea	7/32" or 1/4", 2'X4' plywood, BC or Luan grade
1 ea	1/4" X 48" hardwood dowel
4 ea	1/2" schedule 40 PVC pipe, 5 ft long
2 ea	3/4" schedule 40 PVC pipe, 5 ft long
2 ea	1" schedule 40 PVC pipe, 5 ft long
1 ea	4" PVC solid sewer pipe, SDR 35, 4 ft long (without integral coupling)
10 ea	1/2" PVC 90 degree elbow (slip)
10 ea	1/2" PVC tee (slip)
10 ea	3/4" PVC 90 degree elbow (slip)
10 ea	3/4" PVC tee (slip)
6 ea	1" PVC 90 degree elbow (slip)
6 ea	1" PVC tee (slip)
1 ea	regular PVC cement, 4 oz
2 ea	1" X 4" #2 whitewood, 2 ft long
4 ea	2.5" X 5/8" iron ZN, corner angle bracket with 4 screws
4 ea	2" X 3/8" iron ZN, flat angle bracket with 4 screws
2 ea	hose clamp, #4 1/4"-5/8" diameter
1 ea	3/4" metal pipe hanger tape, 24 gauge, 10 ft long
2 ea	2.5"H X 1.69"W X 0.083" narrow hinge w/removable pin & 6 screws
2 ea	1.5"H X 1.41"W X 0.047" narrow hinge w/nonremovable pin & 4 screws
1 ea	extension spring for heavy doors, 13/32"OD, 0.0625" wire diameter, steel
4 ft	1/4" polypropylene covered shock cord (color optional)
16 ft	18 gauge stranded copper wire, insulated, 2 conductor, unshielded cable
10 ea	11" natural cable tie
5 ft	3/4" nylon sticky back hook and loop fastener
1 ea	vinyl electrical tape, 3/4" wide, 60 ft
1 ea	all purpose duct tape, 2" wide, 60 yd, (color optional)
1 ea	#18 twisted nylon seine twine, 160 ft long
1 ea	nut/bolt locker, 0.2 oz (e.g., Loctite, On the Spot, etc.)
1 ea	carpenters wood glue, 4 oz
1 ea	5 minute epoxy, 1 oz
1 ea	aluminum grid for 5 gallon bucket
1 ea	1/4"-20 threaded rod, 3' long, steel
25 ea	1/4"-20 hex nut, steel
1 ea	3/8"-16 threaded rod, 3' long, steel
20 ea	3/8"-16 hex nut, steel
100 ea	#8-32 X 1 1/4" machine screw, steel, pan head, phillips
100 ea	#8-32 machine screw nuts, steel
20 ea	#10-32 X 1 1/2" machine screws, steel, round head, phillips
20 ea	#10-32 X 1 1/2" machine screw nuts, steel

2004 BEST Consumable List Continued (provided by hub)

10 ea	#4-40 X 1" machine screws, round head, steel
10 ea	#4-40 X 1" machine screw nuts, steel
100 ea	#8 X 1" sheet metal screw, steel, hex head
10 ea	#4 X 3/4" wood screw, steel, slotted drive, round head
100 ea	#6 X 1" wood screws, steel, flat head
20 ea	1/4" SAE flat washer, steel
30 ea	#8 medium split lock washer, steel
25 ea	1/4" medium split lock washer, steel
30 ea	#10 flat washer, steel
30 ea	3/8" lockwasher medium split, steel
10 ea	wood screw eyebolts, 0.192 wire dia x .97 shank x .75 thread x .27 id, steel
3 ea	piano wire, 0.063" diameter, 2' long
6 ea	snap-plug terminals (bullet connectors), insulated, male
1 ea	6" x 6" steel turntable, 500 lb capacity
4 ea	mini snap acting switches, SPDT, 10 amp (min)
1 ea	1/4" polypropylene sheet 12" X 24"
1 ea	1/8" polycarbonate sheet 12" X 24"
1 ea	0.5" thick X 6" wide 6061-T6 aluminum flat, 6" long
1 ea	0.063" thick 5052-H32 aluminum sheet, 12" x 24"
1 ea	0.5" diameter 6061-T6 aluminum round, 24" long
2 ea	0.25" diameter AISI 1018 steel round, 24" long
1 ea	bicycle inner tube (26" X 1.5" - 2.0")
1 ea	60x65" universal brake cable with housing (white or black)

Approved Optional Items (provided by team)

Qty	Description
10 ea	wooden spring type clothes pins
2400 sq in	corrugated cardboard, less than 1/4" thick
2 ea	empty aluminum soft drink cans
3 ea	wire coat hangers with or without plastic coating, less than 1/8" dia
3 ea	solid core golf balls
1 ea	5 minute epoxy, 1 oz
1 ea	2 lb. 7 oz empty coffee can with plastic lid
1 ea	4 oz. PVC primer
144 sq in	heavy duty aluminum foil
6 ea	wooden golf tees
1 ea	aluminum paint grid for 5 gallon bucket
1 ea	inner tube repair kit
4 ea	compact disk (standard size: 120mm diameter x 1.2 mm thick)